



SPECIFICATIONS FOR REFOND SURFACE MOUNT LED

Model: **RF-WNFA50DS-FF**

Company Name: _____

Confirmed By
Customer: _____

DATE: _____

深圳市瑞豐光電子有限公司

SHENZHEN REFOND OPTOELECTRONICS CO.,LTD.

深圳市南山区松白路百旺信工业园二区第6栋

6th wing, 2nd Block of BaiWangXing Industry Park,

Songbai Road,Nanshan District ShenZhen,China,P.C:518108

TEL:0755-29675000

FAX:0755-29675111

<http://www.refond.com>

Feature

- ◆ Viewing angle:120 deg
- ◆ The materials of the LED dice is InGaN
- ◆ 5.30mm×5.00mm×1.60mm SMT-LED
- ◆ RoHS compliant lead-free soldering compatible

Package Outline

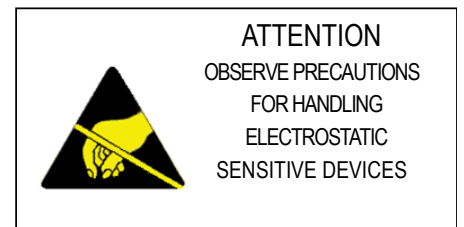
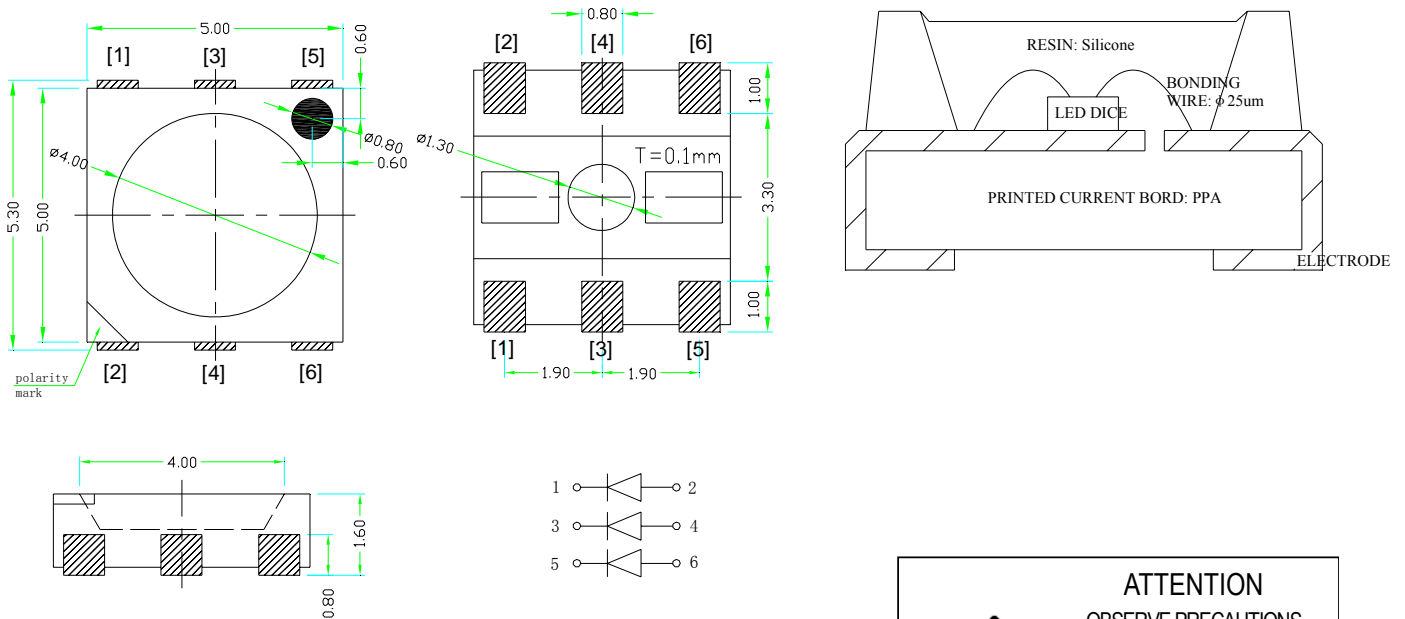

NOTES:

1. All dimensions are in millimeters (inches);
2. Tolerances are $\pm 0.2\text{mm}$ (0.008inch) unless otherwise noted.

| | | | | | |
|--------------|--|-------------|--|--------------|--|
| APPROVED BY: | | CHECKED BY: | | PREPARED BY: | |
| DATE: | | DATE: | | DATE: | |

Absolute maximum ratings at Ta=25°C

| Parameter | Symbol | Value | Unit |
|--------------------------------|--------|-----------|------|
| Power dissipation per chip | Pd | 105 | mW |
| Forward current per chip | If | 30 | mA |
| Reverse voltage per chip | Vr | 5 | V |
| Operating temperature range | Top | -40 ~+100 | °C |
| Storage temperature range | Tstg | -40~+100 | °C |
| Pulse Forward Current per chip | Ifp | 100 | mA |
| Electrostatic Discharge | ESD | 1000(HBM) | V |

Electro-optical characteristics at Ta=25°C

| Parameter | Test Condition | Symbol | Value | | | Unit |
|--------------------|----------------|--------|-------|------|-------|------|
| | | | Min. | Typ. | Max. | |
| Forward voltage | If=60mA | Vf | 2.9 | -- | 3.5 | V |
| Luminous intensity | If=60mA | Iv | 5.4 | 6.6 | 7.3 | cd |
| luminous flux | If=60mA | Φ | 17 | 20 | 23 | lm |
| Chromaticity | If=60mA | CIE X | 0.31 | 0.33 | 0.345 | |
| | If=60mA | CIE Y | 0.31 | 0.35 | 0.384 | |

NOTE: (Tolerance: Iv ±10%, λd ±2nm, Vf ±0.05V)

IFP Conditions: Pulse Width ≤ 10msec. and Duty ≤ 1/10.

Color Ranks

| | Rank FF0 | | | |
|---|----------|--------|--------|--------|
| X | 0.312 | 0.3111 | 0.3173 | 0.3179 |
| Y | 0.3104 | 0.3154 | 0.3257 | 0.3202 |

| | Rank FF9 | | | |
|---|----------|--------|--------|--------|
| X | 0.3111 | 0.3098 | 0.3164 | 0.3173 |
| Y | 0.3154 | 0.3225 | 0.3343 | 0.3257 |

| | Rank FF1 | | | |
|---|----------|--------|--------|--------|
| X | 0.3173 | 0.3164 | 0.3263 | 0.3267 |
| Y | 0.3257 | 0.3343 | 0.3523 | 0.3415 |

| | Rank FF2 | | | |
|---|----------|--------|--------|--------|
| X | 0.3179 | 0.3173 | 0.3267 | 0.327 |
| Y | 0.3202 | 0.3257 | 0.3415 | 0.3338 |

| | Rank FF3 | | | |
|---|----------|--------|--------|--------|
| X | 0.3267 | 0.3263 | 0.3374 | 0.3367 |
| Y | 0.3415 | 0.3523 | 0.3723 | 0.3581 |

| | Rank FF4 | | | |
|---|----------|--------|--------|--------|
| X | 0.327 | 0.3267 | 0.3367 | 0.3361 |
| Y | 0.3338 | 0.3415 | 0.3581 | 0.3473 |

| | Rank FF5 | | | |
|---|----------|--------|--------|--------|
| X | 0.3367 | 0.3374 | 0.348 | 0.3471 |
| Y | 0.3581 | 0.3723 | 0.3885 | 0.3737 |

| | Rank FF6 | | | |
|---|----------|--------|--------|--------|
| X | 0.3361 | 0.3367 | 0.3471 | 0.3464 |
| Y | 0.3473 | 0.3581 | 0.3737 | 0.362 |

| | Rank FF7 | | | |
|---|----------|--------|--------|--------|
| X | 0.3471 | 0.348 | 0.3554 | 0.3544 |
| Y | 0.3737 | 0.3885 | 0.3999 | 0.3846 |

| | Rank FF8 | | | |
|---|----------|--------|--------|--------|
| X | 0.3464 | 0.3471 | 0.3544 | 0.3535 |
| Y | 0.362 | 0.3737 | 0.3846 | 0.3719 |

The C.I.E 1931 Chromaticity diagram

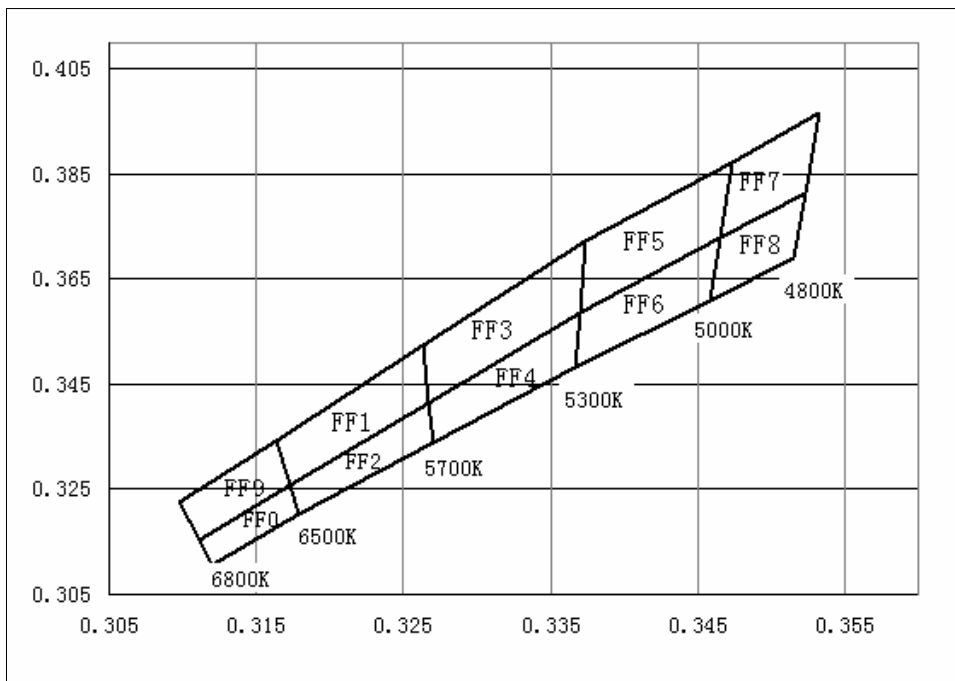

Typical optical characteristics curves

Spectral Distribution

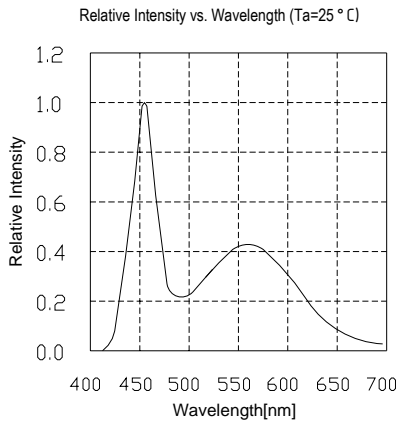

Forward Voltage vs. Forward Current (Ta=25 °C)

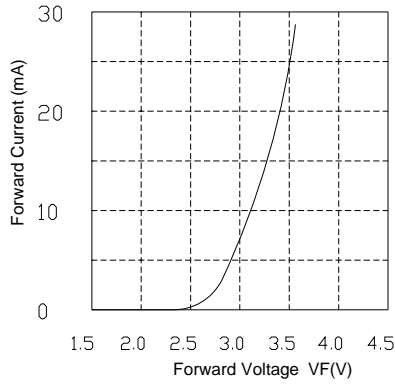

Relative Intensity vs. Forward Current (Ta=25 °C)

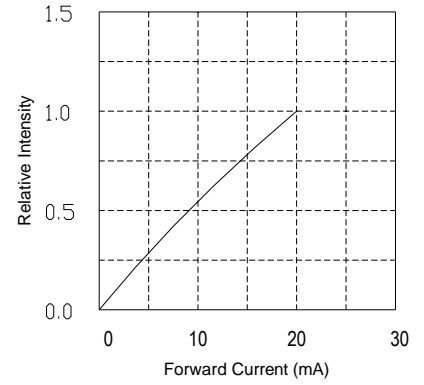

Derating

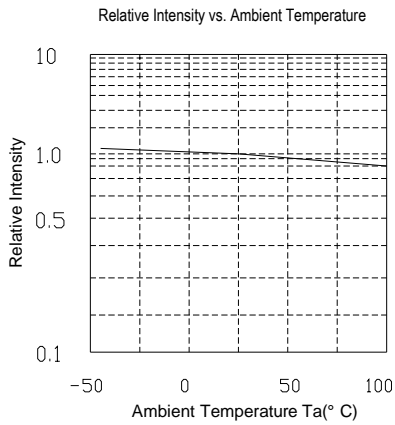

Ambient Temperature vs. Maximum Forward Current

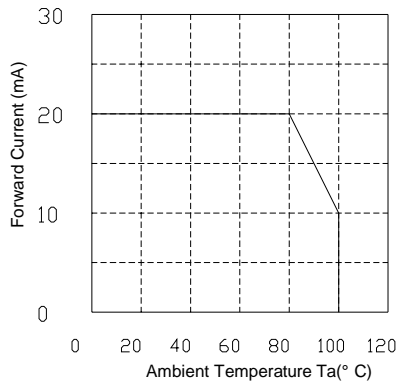

Forward Current vs. Chromaticity (Ta=25 °C)

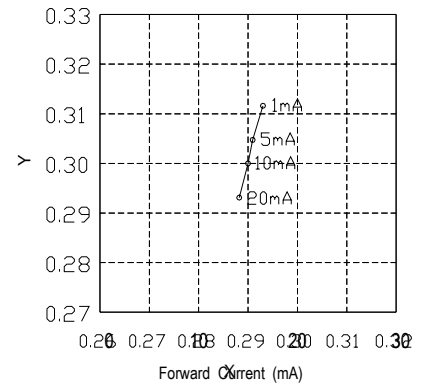
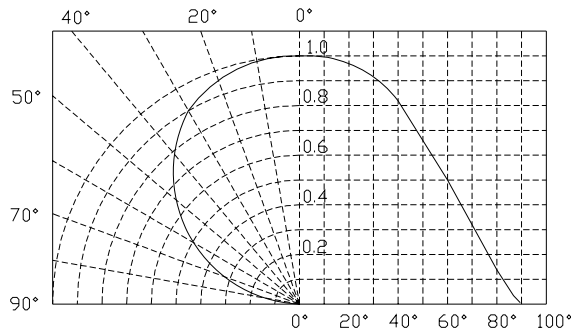

Diagram characteristics of radiation



Reflow profile

■ Soldering condition

- Recommended soldering conditions

| Reflow Soldering | | Hand Soldering | |
|------------------|------------------------------|----------------|----------------------------------|
| Pre-heat | 160~180°C | Temperature | 300°C Max. |
| Pre-heat time | 120 seconds Max. | Soldering time | 3 second Max. (one time only) |
| Peak temperature | 260°C Max. | | |
| Soldering time | 10 seconds Max. | | |
| Condition | Refer to Temperature-profile | | |

- After reflow soldering rapid cooling should be avoided

■ Temperature-profile (Surface of circuit board)

Use the following conditions shown in the figure.

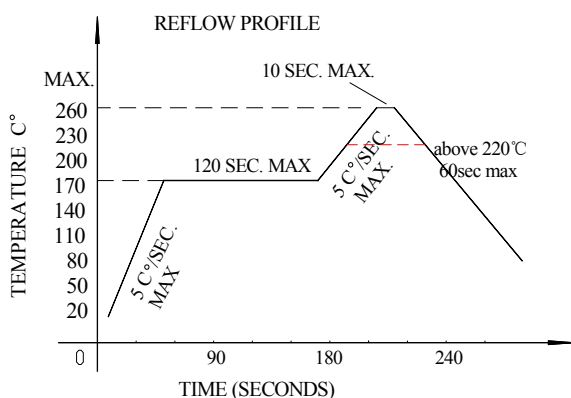

RECOMMEND PAD DESIGN (Units: mm)

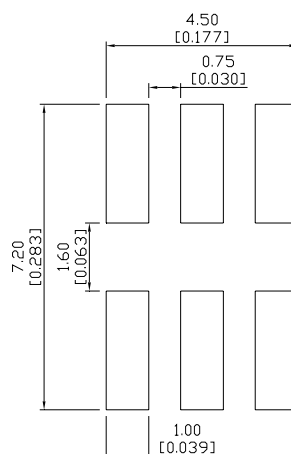

1. Reflow soldering should not be done more than two times
2. When soldering ,do not put stress on the LEDs during heating

■ Soldering iron

1. When hand soldering, keep the temperature of the iron under 300°C, and at that temperature keep the time under 3 sec.
2. The hand soldering should be done only a time
3. The basic spec is ≤ 5 sec. when the temperature of 260°C, do not contact the resin when hand soldering

■ Rework

1. Customer must finish rework within 5 sec under 260°C
2. The head of iron can not touch the resin
3. Twin-head type is preferred.

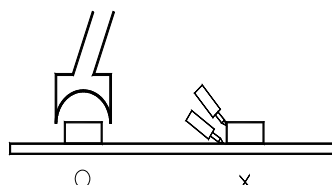

■ CAUTIONS

The encapsulated material of the LEDs is silicone . Therefore the LEDs have a soft surface on the top of package. The pressure to the top surface will be influence to the reliability of the LEDs. Precautions should be taken to avoid the strong pressure on the encapsulated part. So when using the picking up nozzle, the pressure on the silicone resin should be



proper.

Reliability

(1) TEST ITEMS AND RESULTS

| Type | Test Item | Ref. Standard | Test Conditions | Note | Number of Damaged |
|------------------------|------------------------------------------------|---------------|-----------------------------------------------------------|------------|-------------------|
| Environmental Sequence | Resistance to Soldering Heat(Reflow Soldering) | JESD22-B106 | Tsld=260°C,10sec | 2 times | 0/22 |
| | Temperature Cycle | JESD22-A104 | -40°C 30min ↑↓5min 100°C 30min | 1000 cycle | 0/100 |
| | Thermal Shock | JESD22-A106 | -40°C 15min ↑↓ 100°C 15min | 1000 cycle | 0/100 |
| | High Temperature Storage | JESD22-A103 | T _a =100°C | 1000 hrs | 0/100 |
| | Low Temperature Storage | JESD22-A119 | T _a =-40°C | 1000 hrs | 0/100 |
| | Power temperature cycling | JESD22-A105 | On 5min -40°C>15min ↑↓ ↑↓<15min Off5min 100°C>15min | 100 cycle | 0/100 |
| Operation Sequence | Life Test | JESD22-A108 | T _a =25°C I _F =30mA | 1000 hrs | 0/100 |
| | High Humidity Heat Life Test | JESD22-A101 | 60°C RH=90% I _F =20mA | 1000 hrs | 0/100 |

(2) CRITERIA FOR JUDGING THE DAMAGE

| Item | Symbol | Test Conditions | Criteria for Judgement | |
|--------------------|--------|-----------------|------------------------|-------------|
| | | | Min. | Max. |
| Forward Voltage | VF | IF=10mA | - | U.S.L*)×1.1 |
| Reverse Current | IR | VR=5V | - | U.S.L*)×2.0 |
| Luminous Intensity | IV | IF=10mA. | L.S.L**)×0.7 | - |

U.S.L.: Upper Standard Level

L.S.L.: Lower Standard Level

Packaging Specifications

● Feeding Direction

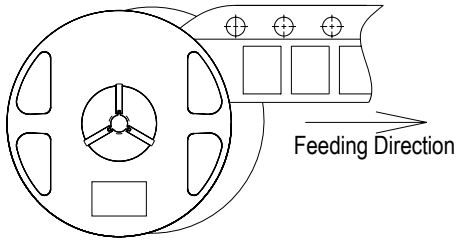

● Dimensions of Reel (Unit: mm)

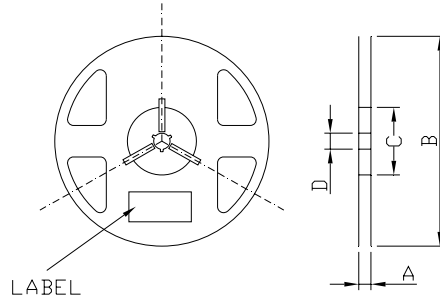

| | |
|---|--------------|
| A | 12 ± 0.1mm |
| B | 178 ± 1mm |
| C | 60 ± 1mm |
| D | 13.0 ± 0.5mm |

● Dimensions of Tape (Unit: mm)

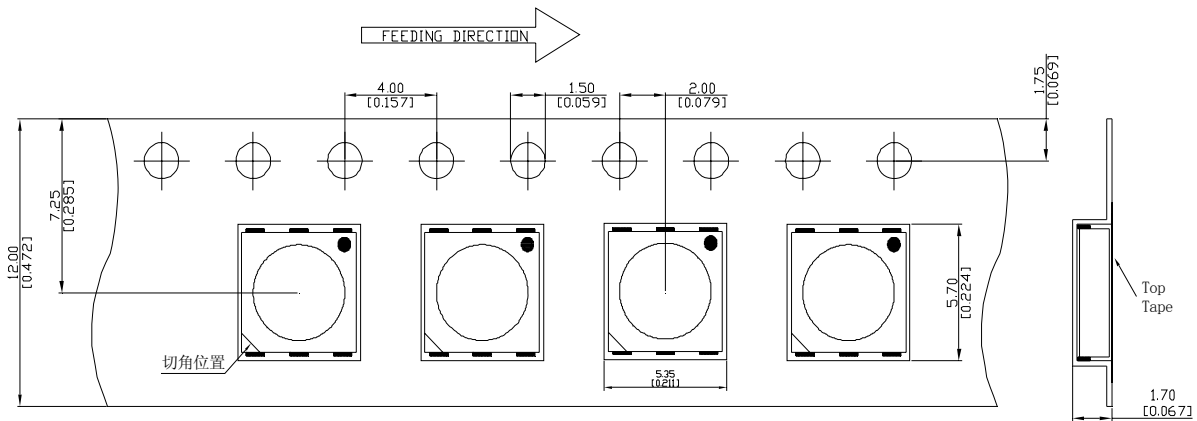

● Arrangement of Tape

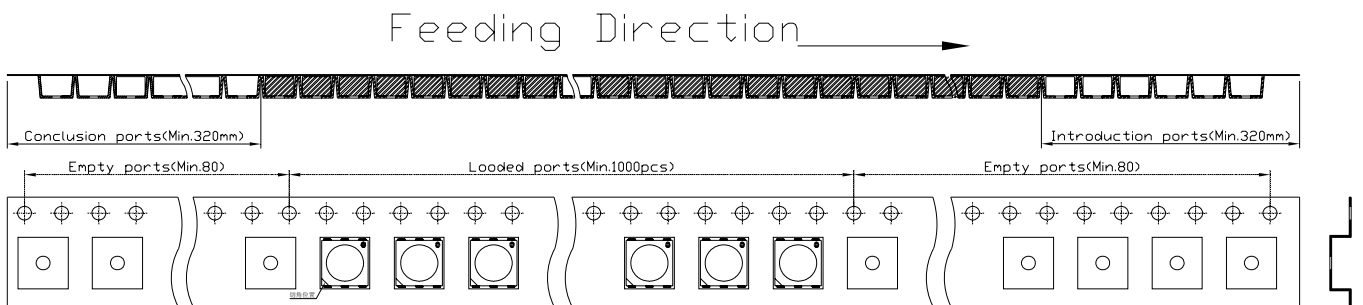



NOTES

1. Empty component pockets are sealed with top cover tape;
2. The maximum number of missing lamps is two;
3. The cathode is oriented towards the tape sprocket hole in accordance with ANSI/EIA RS-481 specifications.
4. 1,000 pcs/ Reel.

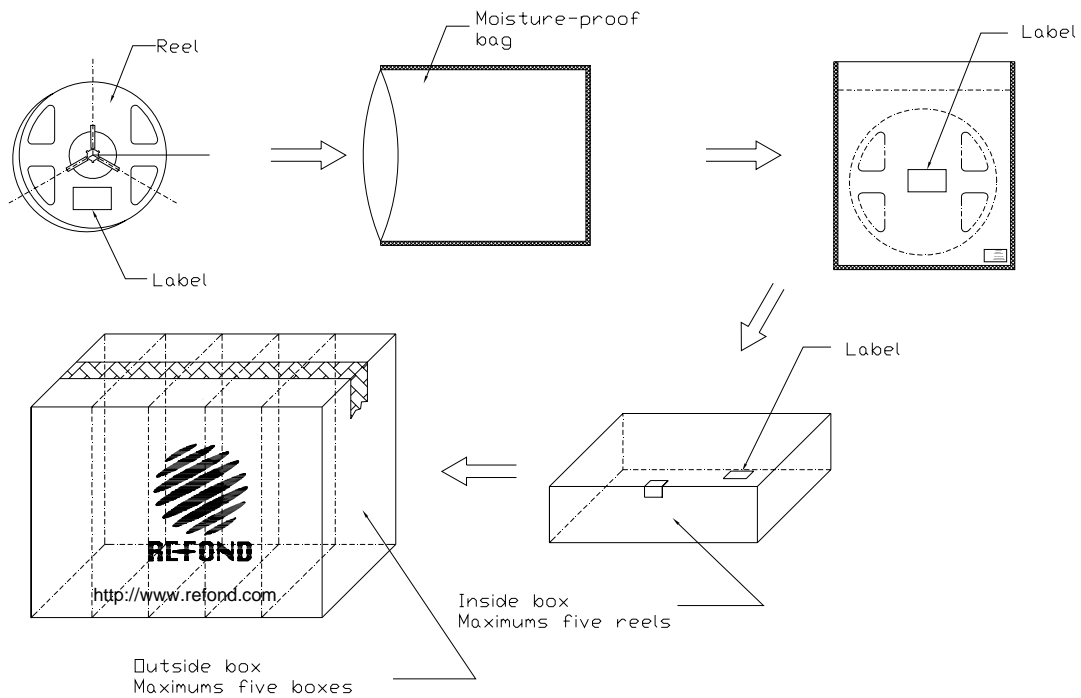
Packaging specifications



■ Label

| | |
|--------------------------------------------------------------------------------------|-------------|
| PART NO. | |
|  | |
| LOT NO. | |
|  | |
| BIN CODE: | |
|  | QTY: PCS |
| | DATE: |

CAUTIONS

Package specifications

Reeled products (numbers of products are 1,000pcs) packed in a seal off moisture-proof bag along with a desiccant one by one, Four moisture-proof bag of maximums (total maximum number of products are 4,000pcs) packed in an inside box (size: about 250mm x about 250 x about 68mm) and Five inside boxes of maximums are put the outside box (size: about 360mm x about 265mm x about 255mm) Together with buffer material, and it is packed. (Part No., Lot No., quantity should appear on the label on the moisture-proof bag, part No. And quantity should appear on the label on the cardboard box.) The number of the loading steps of outside box (cardboard box) has three steps.